

7 Circuits, Transmission Lines, and Waveguides

Electric and magnetic fields contain energy, which can propagate. These are the ingredients needed for communications; in this chapter we will look at how electromagnetic energy can be guided. We will start with low-frequency circuits, then progress through transmission lines to high-frequency waveguides.

7.1 CIRCUITS

The elements of an electrical circuit must satisfy Maxwell's equations. In the low-frequency limit this provides a fundamental explanation for the familiar circuit equations. These simple relationships will hold as long as the frequencies are low enough for the size of the circuit to be much smaller than the electromagnetic wavelength. Above this there is a tricky regime in which the entire circuit acts like a distributed antenna, and then when the wavelength becomes small compared to the size of the circuit things become simpler again (this is the subject of Chapter 9 on optics).

7.1.1 Current and Voltage

The *voltage* or *potential* difference between two parts of a circuit is defined by the line integral of the electric field

$$V = - \int \vec{E} \cdot d\vec{l} \quad . \quad (7.1)$$

As long as $d\vec{B}/dt = 0$ then $\nabla \times \vec{E} = 0$, which implies that the electric field is the gradient of a potential and the value of its line integral is independent of the path; it can go through wires or free space as needed and will always give the same answer. Conversely, if there are time-varying magnetic fields then the potential difference does depend on path and can no longer be defined as a function of position alone.

The electric field is defined to point from positive to negative charge so that the potential increases along a path from negative to positive charge. A charge q such as an electron in a wire feels a force $\vec{F} = q\vec{E}$, and so according to these definitions electrons flow from low to high potentials (Figure 7.1). The *current* \vec{I} , in amperes, at a point in a wire is equal to the number of coulombs of charge passing that point per second. It is defined to be in the same direction as the electric field and hence opposite to the direction in which electrons travel. The current density \vec{J} is equal to the current divided by its cross-sectional area $\vec{J} = \vec{I}/A$.

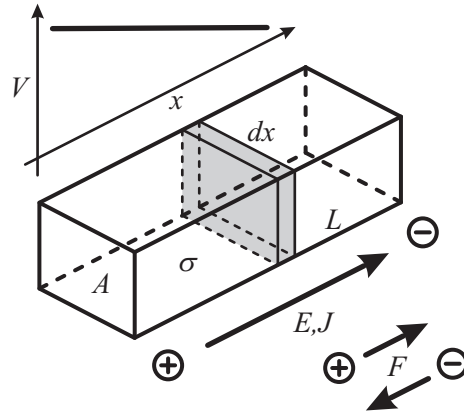

Figure 7.1. A resistive element, showing the relations among the voltage, electric field, current, and charge motion.

7.1.2 Kirchhoff's Laws

There are two *Kirchhoff Laws* that can be used to analyze the current flow in a circuit:

- *The sum of currents into and out of a circuit node must be zero.*
If multiple wires meet at a point, the sum of all their currents must be equal to zero. This is just a statement of the conservation of charge.
- *The sum of voltages around a circuit must vanish.*

This follows because the line integral of the electric field around a closed path

$$V = - \oint \vec{E} \cdot d\vec{l} = - \int \nabla \times \vec{E} \cdot d\vec{A} = \frac{\partial}{\partial t} \int \vec{B} \cdot d\vec{A} \quad (7.2)$$

will vanish if there is no time-varying magnetic flux linking the circuit.

7.1.3 Resistance

In an isotropic conductor the current and electric field are related by

$$\vec{J} = \sigma \vec{E} \quad , \quad (7.3)$$

where σ is the material's *conductivity*. For very large fields there may be nonlinear deviations from this linear relationship, and in a complex material the conductivity may be a tensor that depends on direction. The voltage drop across the resistor in Figure 7.1 with length L , cross-sectional area A , conductivity σ , and carrying a current I is therefore

$$V = - \int_{-}^{+} \vec{E} \cdot d\vec{x} = - \int_{-}^{+} \frac{\vec{J}}{\sigma} \cdot d\vec{x} = \int_{-}^{+} \frac{I}{\sigma A} dx = \frac{IL}{\sigma A} \equiv IR \quad . \quad (7.4)$$

Remember that the integral goes from low to high potential, but that current flows from high to low potentials, so $-\vec{J} \cdot d\vec{x} = J dx = I dx/A$. This is just *Ohm's Law*, and it defines the *resistance*

$$R = \frac{L}{\sigma A} = \frac{\rho L}{A} \quad (7.5)$$

in terms of the conductivity σ , which has units of siemens per meter (S/m), or the *resistivity* ρ , which has units of ohm-meters ($\Omega\cdot\text{m}$). For a two-dimensional film of thickness T , the resistance of a region of length L and width W is

$$\begin{aligned} R &= \rho \frac{L}{A} \\ &= \rho \frac{L}{TW} \\ &= \frac{\rho}{T} \frac{L}{W} \\ &\equiv R_{\square} \frac{L}{W} \end{aligned} \quad (7.6)$$

This defines the *sheet resistivity* R_{\square} (“R square”). Since L/w is dimensionless, R_{\square} has units of resistance without any other length.

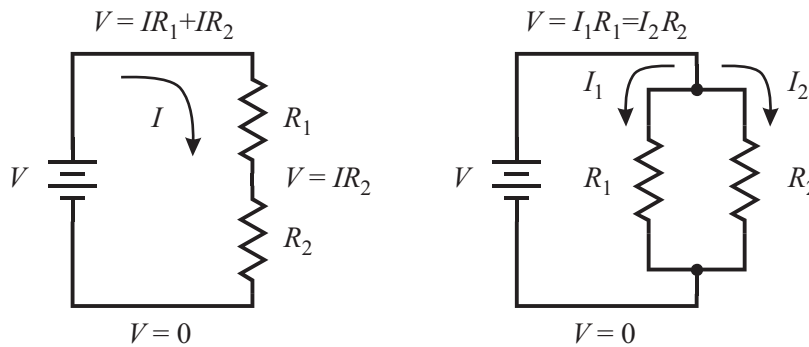

Figure 7.2. Series and parallel circuits.

Kirchhoff's Laws can be used to simplify the circuits in Figure 7.2. For the series circuit on the left,

$$V = IR_1 + IR_2 \quad (7.7)$$

or

$$I = \frac{V}{R_1 + R_2} \quad (7.8)$$

therefore the total resistance is

$$R_{\text{total}} = R_1 + R_2 \quad (7.9)$$

Series resistances simply add. For the parallel circuit on the right, the voltage drop across both legs must be equal since potential is independent of path,

$$V = I_1R_1 = I_2R_2 \quad (7.10)$$

and the current in both legs must add up to the total current

$$I_1 + I_2 = \frac{V}{R_{\text{total}}} \quad (7.11)$$

Therefore

$$\frac{V}{R_1} + \frac{V}{R_2} = \frac{V}{R_{\text{total}}} \quad (7.12)$$

or

$$\frac{1}{R_{\text{total}}} = \frac{1}{R_1} + \frac{1}{R_2}$$

$$R_{\text{total}} = \frac{R_1 R_2}{R_1 + R_2} \quad (7.13)$$

Parallel resistances add inversely. More complex networks of resistances can always be simplified to a single effective resistance by repeated application of these rules.

7.1.4 Power

Now let's now consider a slab of charge of cross-sectional area A and thickness dx moving through the resistor in Figure 7.1. If the charge density is ρ_q , the total charge in this slab is $Q = \rho_q dx A$ and it feels a net force $\vec{F} = Q\vec{E}$. Because a current is flowing, charge is moving relative to this force and so work is being done. The work associated with the slab moving from one end of the resistor to the other is equal to the integral of the force times the displacement:

$$dW = \int_{-}^{+} \vec{F} \cdot d\vec{x} = -Q \int_{-}^{+} \vec{E} \cdot d\vec{x} = -QV = -\rho_q dx AV \quad (7.14)$$

for a negative charge. This decrease in energy is dissipated in the resistor; the *power* is equal to the rate at which work is being done

$$P = -\frac{dW}{dt} = \rho_q \frac{dx}{dt} AV = JAV = IV = I^2 R \quad (7.15)$$

The power dissipated in a resistor is equal to the current flowing through it times the voltage drop across it, which by Ohm's Law is also equal to the square of the current times the resistance. This appears as heat in the resistor.

7.1.5 Capacitance

There will be an electric field between an electrode that has a charge of $+Q$ on it and one that has a charge of $-Q$, and hence a potential difference between the electrodes. *Capacitance* is defined to be the ratio of the charge to the potential difference:

$$C = \frac{Q}{V} \quad (7.16)$$

The MKS unit is the *farad*, F. Capacitances range from picofarads in circuit components up to many farads in *supercapacitors* based on electrochemical effects [Conway, 1991].

The current across a capacitor is given by

$$C \frac{dV}{dt} = \frac{dQ}{dt} = I \quad (7.17)$$

A capacitor is a device that stores energy in an electric field by storing charge on its plates; in Problem 6.2 we saw that this stored energy is equal to $CV^2/2$. The current flowing

across a capacitor is a *displacement current*: from the point of view of the overall circuit it is a real current, but it arises from the time-varying electric field associated with the capacitor plates storing or releasing charge rather than from real charge passing through the capacitor.

If the applied voltage is $V = e^{i\omega t}$, then the current is

$$I = C \frac{dV}{dt} = i\omega C e^{i\omega t} \quad . \quad (7.18)$$

The *impedance* (complex resistance) is defined to be the ratio of the voltage and current at a fixed frequency,

$$Z = \frac{V}{I} = \frac{e^{i\omega t}}{i\omega C e^{i\omega t}} = \frac{1}{i\omega C} \quad . \quad (7.19)$$

The current leads the voltage by a phase shift of $i = 90^\circ$. When $\omega = 0$ the impedance is infinite (no current flows at DC), and when $\omega = \infty$ the impedance is 0 (the capacitor acts like a wire).

7.1.6 Inductance

An *inductor* stores energy in a magnetic field arising from current flowing through a coil. The inductance is defined to be the ratio of the magnetic flux

$$\Phi = \int \vec{B} \cdot d\vec{A} \quad (7.20)$$

linking a circuit to the current that produces it:

$$L = \frac{\Phi}{I} \quad . \quad (7.21)$$

The MKS unit of inductance is the *henry*, H.

In Figure 7.3 the electric field vanishes along the dotted line for an ideal solenoid, therefore the line intergral of the electric field along the dotted line and around the solenoid is equal to the voltage drop across the solenoid. And the magnetic field vanishes outside the solenoid if it is approximated to be a section of an infinite solenoud, therefore the integral of the magnetic field across the surface bounded by the path is equal to the flux linking the solenoid times the number of turns of the coil. This lets us relate the flux to the potential. If this ideal solenoid is taken to have just a single turn then

$$-V = \oint \vec{E} \cdot d\vec{l} = -\frac{\partial}{\partial t} \int_S \vec{B} \cdot d\vec{A} = -\frac{\partial \Phi}{\partial t} = -\frac{\partial}{\partial t}(LI) = -L \frac{dI}{dt} \quad (7.22)$$

and so

$$V = L \frac{dI}{dt} \quad . \quad (7.23)$$

Extra turns add in series: if an inductor has N turns, then the inductance is N times that due to one turn, assuming that the flux linking all the turns is the same. Since the field of a solenoid of radius r and length l with n turns/meter is $H = nI$, the inductance is

$$L = \frac{\Phi}{I} = \frac{N}{I} \int \vec{B} \cdot d\vec{A} = \frac{nl}{I} \mu n I \pi r^2 = \mu n^2 l \pi r^2 \quad . \quad (7.24)$$

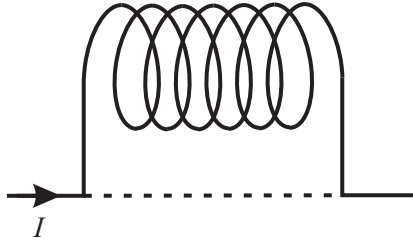

Figure 7.3. A solenoid; the dotted line closes the integration path.

Problem 6.3 showed that the energy stored in a solenoid is $LI^2/2$.

If the current flowing through an inductor is $I = e^{i\omega t}$ then the voltage drop across it is $V = Li\omega e^{i\omega t}$, and so the impedance is

$$Z = \frac{Li\omega e^{i\omega t}}{e^{i\omega t}} = i\omega L \quad . \quad (7.25)$$

The current lags the voltage by 90° ($-i$).

7.2 WIRES AND TRANSMISSION LINES

We have been considering conduction in the low-frequency limit; in this section we will use Maxwell's equations to look at how AC fields penetrate conductors and are guided by them at higher frequencies.

7.2.1 Skin Depth

Assume that the conductor is described by $\vec{J} = \sigma\vec{E}$, $\vec{D} = \epsilon\vec{E}$, $\vec{B} = \mu\vec{H}$. If the electric field is periodic as $\vec{E}(\vec{x}, t) = \vec{E}(\vec{x})e^{i\omega t}$ then the curl of the magnetic field is

$$\begin{aligned} \nabla \times \vec{H} &= \vec{J} + \frac{\partial \vec{D}}{\partial t} \\ \nabla \times \vec{B} &= \mu\sigma\vec{E} + \mu\epsilon\frac{\partial \vec{E}}{\partial t} \\ \nabla \times \vec{B}(\vec{x}) &= (\mu\sigma + i\omega\mu\epsilon)\vec{E}(\vec{x}) \quad . \end{aligned} \quad (7.26)$$

Since the divergence of a curl vanishes,

$$\begin{aligned} \nabla \cdot \nabla \times \vec{B} &= 0 = (\mu\sigma + i\omega\mu\epsilon)\nabla \cdot \vec{E} \\ \Rightarrow \nabla \cdot \vec{E} &= \frac{\rho}{\epsilon} = 0 \quad . \end{aligned} \quad (7.27)$$

The linear response coefficients require that there be no free charge.

Now taking the curl of the curl of \vec{E} ,

$$\nabla \times \vec{E} = -\frac{\partial \vec{B}}{\partial t}$$

$$\begin{aligned}\nabla \times \nabla \times \vec{E} &= -\frac{\partial}{\partial t} \nabla \times \vec{B} \\ \underbrace{\nabla(\nabla \cdot \vec{E})}_0 - \nabla^2 \vec{E} &= -\mu\sigma \frac{\partial \vec{E}}{\partial t} - \mu\epsilon \frac{\partial^2 \vec{E}}{\partial t^2} .\end{aligned}\quad (7.28)$$

The first term on the right hand side is due to real conduction, and the second term is due to the displacement current. Since σ is very large in a good conductor, up to very high (optical) frequencies the displacement current term can be dropped:

$$\nabla^2 \vec{E} = \mu\sigma \frac{\partial \vec{E}}{\partial t} . \quad (7.29)$$

This is now a diffusion equation instead of a wave equation. For a periodic electric field, the spatial part satisfies

$$\nabla^2 \vec{E}(\vec{x}) = i\omega\mu\sigma \vec{E}(\vec{x}) \equiv k^2 \vec{E}(\vec{x}) . \quad (7.30)$$

Since

$$\sqrt{i} = \frac{1+i}{\sqrt{2}} \quad (7.31)$$

(try squaring it),

$$\begin{aligned}k &= \sqrt{i\omega\mu\sigma} \\ &= (1+i)\sqrt{\frac{\omega\mu\sigma}{2}} \\ &\equiv \frac{1+i}{\delta} .\end{aligned}\quad (7.32)$$

This defines the *skin depth*

$$\delta = \sqrt{\frac{2}{\omega\mu\sigma}} = \frac{1}{\sqrt{\pi\nu\mu\sigma}} \quad (7.33)$$

in terms of the frequency ν , the permeability μ , and the conductivity σ .

Consider the solution to equation (7.30) for a plane wave incident on the surface of a conductor, so that by symmetry we need consider only the distance z into the conductor

$$\frac{d^2 E}{dz^2} = k^2 E . \quad (7.34)$$

E is the magnitude of the electric field, which for a plane wave is transverse to the direction of z . This is solved by

$$E(x) = E_0 e^{-kz} = E_0 e^{-z/\delta} e^{-iz/\delta} , \quad (7.35)$$

where E_0 is the amplitude at the surface, and we've ignored the unphysical possible solution e^{kz} . The total current per unit width that is produced by this field is found by integrating the current density over the depth

$$I = \int_0^\infty J dz = \int_0^\infty \sigma E dz = \int_0^\infty \sigma E_0 e^{-kz} dz = \frac{\sigma E_0}{k} . \quad (7.36)$$

Therefore

$$\begin{aligned} E_0 &= \frac{kI}{\sigma} = \frac{1+i}{\sigma\delta} I = \left(\frac{1}{\sigma\delta} + i \frac{1}{\sigma\delta} \right) I \\ &\equiv (R_s + \omega L_s) I \quad . \end{aligned} \quad (7.37)$$

The total current is proportional to the applied field at the surface; the real part of this defines an effective *surface resistance* R_s , and the imaginary part defines the *surface inductance* L_s . Associated with this current there is dissipation; in a small volume of cross-sectional area A and length along the surface L the dissipation per volume is

$$\frac{I_{\text{volume}}^2 R}{AL} = \frac{1}{AL} J^2 A^2 \frac{L}{\sigma A} = \frac{J^2}{\sigma} \quad . \quad (7.38)$$

If the current is periodic, taking a time average introduces another factor of $\langle \sin^2 \rangle = 1/2$:

$$\left\langle \frac{I^2 R}{AL} \right\rangle = \frac{|J|^2}{2\sigma} \quad . \quad (7.39)$$

Integrating this from $z = 0$ to ∞ gives the energy dissipated by the field in the material per surface area

$$\int_0^\infty \frac{|J|^2}{2\sigma} dz = \int_0^\infty \frac{\sigma^2 E_0^2}{2\sigma} e^{2z/\delta} dz = \frac{\sigma E_0^2 \delta}{4} \quad . \quad (7.40)$$

The amplitude of the field and current are falling off exponentially with a length scale equal to the skin depth. For example, pure copper at room temperature has a conductivity of 5.8×10^7 S/m and so $\delta \sim 7$ cm at 1 Hz, 2 mm at 1 kHz, 70 μm at 1 MHz, and 2 μm at 1 GHz. Since the skin depth is so small at even fairly low frequencies, very little thickness is needed to screen a field. This is why it is a good approximation to assume that fields vanish at the surface of a conductor, which we have already found to be the boundary condition for a perfect conductor. The part of the field that does leak into the conductor causes a current to flow, and this current leads to resistive dissipation, therefore in making this approximation we are leaving out the mechanism that damps fields around conductors. This is very important in resonant electromagnetic cavities that are designed to have a high Q (low damping rate).

Because of the skin depth, a bundle of fine wires has a smaller AC resistance than a single fat wire because there is more surface area for the current to penetrate into and the overall resistance will be inversely proportional to the effective cross-sectional area of the bundle. This is why wires carrying high frequency signals are stranded rather than solid.

7.2.2 Transmission Lines

While electromagnetic fields cannot penetrate far into good conductors, they can be guided long distances by them. Distributed objects can have energy stored in electric fields through capacitance, and in magnetic fields by inductance; the interplay between these can give rise to an energy flow. As a first example such a *transmission line*, consider the coaxial cable in Figure 7.4). Other important transmission line geometries include parallel wires or strips (Problem 7.4), and a strip above a ground plane (called a *stripline*).

Because a transmission line is operated in a closed circuit there is no net charge transfer

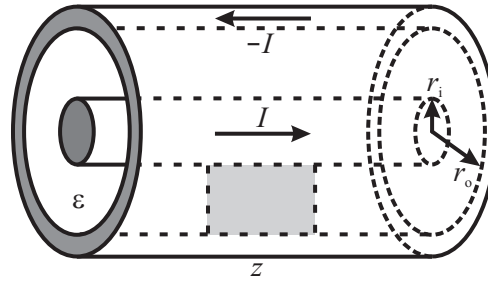
Figure 7.4. A coaxial cable field with a dielectric ϵ .

between either end. We will assume here that any current I in the inner conductor must be matched by a return current $-I$ in the outer conductor; the next section will study higher-frequency modes for which this is no longer true. There is an electric field between the inner and outer conductors, giving rise to a distributed capacitance between them. Current flowing in the inner conductor also produces a magnetic field around it, and hence a distributed inductance along it. As long as the frequency is not so large that the wavelength is comparable to the cross-sectional size, the coaxial cable therefore acts like an extended series inductor and parallel capacitor (Figure 7.5). This circuit model is applicable to arbitrary transmission lines; its solution will reappear in the next section as the fundamental mode for Maxwell's equation in a cylindrical geometry.

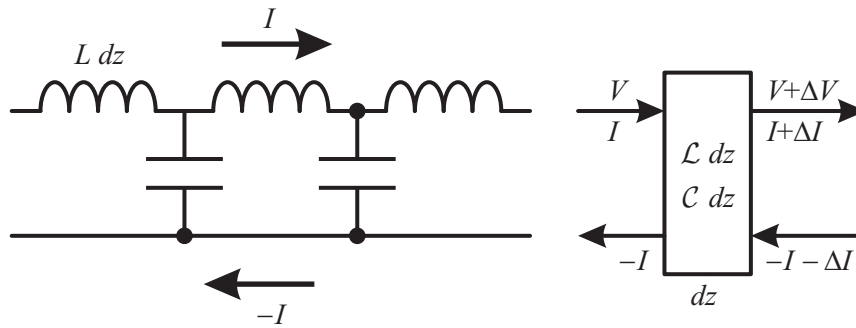

Figure 7.5. Effective circuit model for a transmission line, and a differential element.

From Stokes' Law, the magnetic field between the conductors is

$$H = \frac{I}{2\pi r} \quad , \quad (7.41)$$

and the field vanishes outside of the outer conductor because the net current is then zero. Integrating this field over the surface of length z shown in Figure 7.4 to find the flux between the conductors,

$$\Phi = \int \vec{B} \cdot d\vec{A} = z \int_{r_i}^{r_o} \mu_0 \frac{I}{2\pi r} dr = z \frac{\mu_0 I}{2\pi} \ln \frac{r_o}{r_i} \quad . \quad (7.42)$$

Since the dielectric is non-magnetic we can take $\mu_r \sim 1$. Therefore, the inductance per

length is

$$\mathcal{L} = \frac{\Phi}{zI} = \frac{\mu_0}{2\pi} \ln \frac{r_o}{r_i} \quad \left(\frac{\text{H}}{\text{m}} \right) . \quad (7.43)$$

Similarly, from Gauss' Law the electric field between the conductors is

$$E = \frac{Q}{2\pi\epsilon r} , \quad (7.44)$$

where Q is the charge per unit length and the field vanishes outside of the outer conductor. Integrating to find the potential difference,

$$V = - \int_{r_i}^{r_o} \vec{E} \cdot d\vec{l} = \frac{Q}{2\pi\epsilon} \ln \frac{r_o}{r_i} , \quad (7.45)$$

which gives the capacitance per unit length

$$\mathcal{C} = \frac{Q}{V} = \frac{2\pi\epsilon}{\ln(r_o/r_i)} \quad \left(\frac{\text{F}}{\text{m}} \right) . \quad (7.46)$$

7.2.3 Wave Solutions

Now consider the little differential length of the transmission line dz shown in Figure 7.5, with parallel capacitance $\mathcal{C} dz$ and series inductance $\mathcal{L} dz$. If there is an increase in the current flowing across it

$$\Delta I = \frac{\partial I}{\partial z} dz \quad (7.47)$$

there must be a corresponding decrease in the charge stored in the capacitance

$$\Delta I = -\mathcal{C} dz \frac{\partial V}{\partial t} . \quad (7.48)$$

Therefore

$$\frac{\partial I}{\partial z} dz = -\mathcal{C} dz \frac{\partial V}{\partial t} \quad (7.49)$$

or

$$\frac{\partial I}{\partial z} = -\mathcal{C} \frac{\partial V}{\partial t} . \quad (7.50)$$

Similarly, if there is an increase in the potential across the element

$$\Delta V = \frac{\partial V}{\partial z} dz \quad (7.51)$$

there must be a decrease in the current flowing through the inductance

$$\Delta V = -\mathcal{L} dz \frac{\partial I}{\partial t} . \quad (7.52)$$

Current flows from high to low potential, so an increasing potential drop across the inductor has the opposite sign from the decreasing current. Equating these expressions,

$$\frac{\partial V}{\partial z} = -\mathcal{L} \frac{\partial I}{\partial t} . \quad (7.53)$$

Now take a time derivative of equation (7.50)

$$\frac{\partial^2 I}{\partial t \partial z} = -C \frac{\partial^2 V}{\partial t^2} \quad (7.54)$$

and a z derivative of equation (7.53)

$$\frac{\partial^2 V}{\partial z^2} = -\mathcal{L} \frac{\partial^2 I}{\partial z \partial t} \quad (7.55)$$

and interchange the order of differentiation to equate the mixed terms (which is permitted for well-behaved functions):

$$\frac{\partial^2 V}{\partial z^2} = \mathcal{L}C \frac{\partial^2 V}{\partial t^2} \equiv \frac{1}{v^2} \frac{\partial^2 V}{\partial t^2} \quad , \quad (7.56)$$

where

$$v \equiv \frac{1}{\sqrt{\mathcal{L}C}} \quad . \quad (7.57)$$

This is a wave equation for the voltage in the transmission line. It is solved by an arbitrary distribution traveling with a velocity $\pm v$

$$\begin{aligned} V(z, t) &= f(z - vt) + g(z + vt) \\ &= V_+ + V_- \quad . \end{aligned} \quad (7.58)$$

If we follow a fixed point in the distribution $f(0)$, $z - vt = 0 \Rightarrow z = vt$. The V_+ solution travels to the right, and V_- to the left. For a sinusoidal wave $V = e^{i(kz - \omega t)}$, $k = \omega/v$.

Taking derivatives in the opposite order gives a similar equation for the current:

$$\frac{\partial^2 I}{\partial z^2} = \frac{1}{v^2} \frac{\partial^2 I}{\partial t^2} \quad . \quad (7.59)$$

To relate the voltage to the current, substitute equation (7.58) into equation (7.50)

$$\frac{\partial I}{\partial z} = -C[-vf'(z - vt) + vg'(z + vt)] \quad (7.60)$$

and integrate over z

$$\begin{aligned} I &= Cv[f(z - vt) - g(z + vt)] \\ &\equiv \frac{1}{Z}[f(z - vt) - g(z + vt)] \\ &= \frac{1}{Z}[V_+ - V_-] \\ &= I_+ + I_- \quad , \end{aligned} \quad (7.61)$$

where

$$Z = \frac{1}{Cv} = \sqrt{\frac{\mathcal{L}}{C}} \quad (\Omega). \quad (7.62)$$

The current is proportional to the voltage, with the sign difference in the two terms coming from the difference between the solutions traveling in the right and left directions. The constant of proportionality is the *characteristic impedance* of the transmission line Z . The velocity and impedance of a transmission line are simply related to the capacitance and inductance per unit length. In a real cable, different frequencies are damped at

different rates, changing the pulse shape as it travels, and if there are nonlinearities then different frequencies can travel at different rates causing *dispersion*: a sharp pulse will spread out. The dispersion sets a limit on how close pulses can be and still remain separated after traveling a long distance.

7.2.4 Reflections and Terminations

Consider a transmission line with a characteristic impedance Z_0 terminated by a load impedance Z_L . The load might be a resistor, or it could be another transmission line. For a resistor the impedance is associated with energy dissipated by ohmic heating, and for a transmission line the impedance is associated with energy that is transported away, but in both cases the voltage drop across the element is equal to the current applied to it times its impedance.

The incoming transmission line can support signals traveling in both directions (equation 7.58), therefore the voltage at the discontinuity is the sum of these:

$$V_L(t) = V_+(t) + V_-(t) \quad . \quad (7.63)$$

Similarly, the current across the load is

$$I_L(t) = I_+(t) + I_-(t) \quad . \quad (7.64)$$

The current across the termination must equal the current in the transmission line immediately before the termination:

$$\frac{V_L}{Z_L} = \frac{V_+}{Z_0} - \frac{V_-}{Z_0} \quad . \quad (7.65)$$

Eliminating variables between this and equation (7.63) gives the ratio of the incoming and reflected voltages, called the *reflection coefficient*

$$R = \frac{V_-}{V_+} = \frac{Z_L - Z_0}{Z_L + Z_0} \quad , \quad (7.66)$$

and the ratio of the incoming and the transmitted signals is equal to the *transmission coefficient*

$$T = \frac{V_L}{V_+} = \frac{2Z_L}{Z_L + Z_0} \quad . \quad (7.67)$$

Because of the load, V_+ and V_- can no longer be arbitrarily chosen but must satisfy the boundary conditions. These reflection and transmission coefficients have a number of interesting properties. If the load impedance is 0 (a short), $R = -1$ and so there is a reflected pulse of the same shape but opposite sign. If the load resistance is infinite (it is open), $R = 1$ and the reflected pulse has the same sign. These reflections are used in a *Time Domain Reflectometer (TDR)* to locate cable faults by measuring the time for a return pulse to arrive. Finally, if $Z_L = Z_0$ then $R = 0$: there is no reflection at all! This is why cables carrying high-frequency signals are terminated with resistors that match the cable's characteristic impedance. Such terminations are particularly important to eliminate clutter from reflected pulses in computer networks and buses.

If $V_+(z) = V_0 e^{ikz}$ going into the load,

$$\begin{aligned} V(z) &= V_+(z) + V_-(z) \\ &= V_0 (e^{ikz} + R e^{-ikz}) \end{aligned} \quad (7.68)$$

As a function of z , the positive- and negative-going waves will periodically add to and subtract from each other. Taking the ratio of the maximum to the minimum value for this sum defines the *Voltage Standing-Wave Ratio (VSWR)*

$$\begin{aligned} \text{VSWR} &\equiv \frac{V_{\max}}{V_{\min}} \\ &= \frac{1 + |R|}{1 - |R|} \end{aligned} \quad (7.69)$$

or

$$|R| = \frac{\text{VSWR} - 1}{\text{VSWR} + 1} \quad (7.70)$$

The VSWR is one of the most important measurements in an RF system, used to ensure that impedances are matched so that all of the power goes in the intended direction.

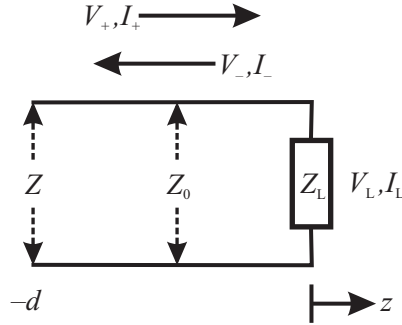

Figure 7.6. A transmission line with impedance Z terminated by a load Z_L .

Now consider the impedance of a transmission line as viewed by a periodic source a distance d from the termination, shown in Figure 7.6:

$$\begin{aligned} Z(-d) &= \frac{V(-d)}{I(-d)} \\ &= \frac{V_+ e^{-ikd} + V_- e^{ikd}}{Z_0^{-1} (V_+ e^{ikd} - V_- e^{-ikd})} \\ &= \frac{V_+ (e^{-ikd} + R e^{ikd})}{V_+ Z_0^{-1} (e^{ikd} - R e^{-ikd})} \\ &= Z_0 \frac{(e^{-ikd} + R e^{ikd})}{(e^{ikd} - R e^{-ikd})} \end{aligned} \quad (7.71)$$

Normalizing this by the characteristic impedance of the transmission line,

$$\frac{Z(-d)}{Z_0} = \frac{e^{-ikd} + R e^{ikd}}{e^{ikd} - R e^{-ikd}}$$

$$\begin{aligned}
&= \frac{1 + Re^{i2kd}}{1 - Re^{i2kd}} \\
r + ic &\equiv \frac{1 + (x + iy)}{1 - (x + iy)} \\
&= \frac{1 - (x^2 + y^2)}{(1 - x)^2 + y^2} + i \frac{2y}{(1 - x)^2 + y^2} \quad , \quad (7.72)
\end{aligned}$$

relates the real and complex parts of the input impedance

$$r + ic = \frac{Z}{Z_0} \quad (7.73)$$

to those of the round-trip reflection coefficient

$$x + iy = Re^{i2kd} \quad . \quad (7.74)$$

The real equation can be rewritten suggestively as

$$\begin{aligned}
r &= \frac{1 - (x^2 + y^2)}{(1 - x)^2 + y^2} \\
\frac{r(1 - x)^2 + x^2}{1 + r} + y^2 &= \frac{1}{1 + r} \\
x^2 - 2x \frac{r}{1 + r} + \frac{r}{1 + r} + y^2 &= \frac{1}{1 + r} \\
x^2 - 2x \frac{r}{1 + r} + \left(\frac{r}{1 + r}\right)^2 + y^2 &= \frac{1}{1 + r} + \left(\frac{r}{1 + r}\right)^2 - \frac{r}{1 + r} \\
\left(x - \frac{r}{1 + r}\right)^2 + y^2 &= \frac{1}{(1 + r)^2} \quad . \quad (7.75)
\end{aligned}$$

In the complex (x, y) plane, the reflection coefficient lies on a circle of radius $1/(1 + r)$ with a center at $(r/(1 + r), 0)$ set by the real part of the input impedance r . Similarly, the complex equation can be rewritten as

$$\begin{aligned}
c &= \frac{2y}{(1 - x)^2 + y^2} \\
(1 - x)^2 + y^2 &= \frac{2y}{c} \\
(1 - x)^2 + y^2 - 2y \frac{1}{c} + \frac{1}{c^2} &= \frac{1}{c^2} \\
(1 - x)^2 + \left(y - \frac{1}{c}\right)^2 &= \frac{1}{c^2} \quad . \quad (7.76)
\end{aligned}$$

This restricts the reflection coefficient to a circle of radius $1/c$ located at $(1, \pm 1/c)$ given by the complex part of the input impedance c . The intersection of these two circles relates the input impedance to the reflection coefficient, conveniently found graphically on a *Smith chart* (Figure 7.7).

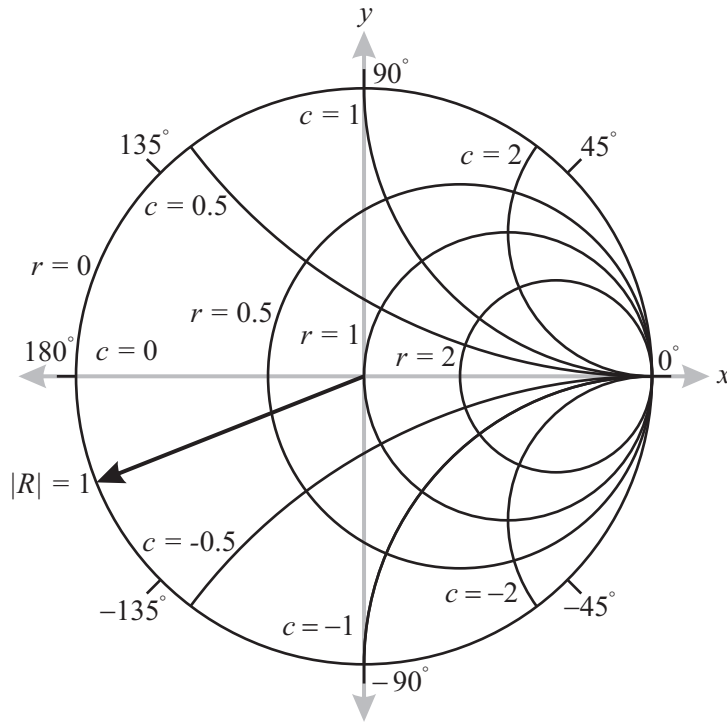

Figure 7.7. The Smith chart.

7.3 WAVEGUIDES

As the wavelength of a signal in a transmission line becomes comparable to the transverse size of the line, more complicated excitations become possible and the circuit model used in the last section no longer applies. A complete solution of Maxwell's equations is then required. Some of these new modes will prove to be desirable, and some will not. *Waveguides*, not surprisingly, guide electromagnetic waves. Depending on the geometry they may or may not be able to transmit a steady current because it is possible to guide waves without a DC return path. Waveguides usually have some symmetry about their long axis; a rectangular pipe is a common type.

7.3.1 Governing Equations

Start with the wave form of Maxwell's equations without any sources:

$$\nabla^2 \vec{E} = \mu\epsilon \frac{\partial^2 \vec{E}}{\partial t^2} \quad \nabla^2 \vec{H} = \mu\epsilon \frac{\partial^2 \vec{H}}{\partial t^2} \quad . \quad (7.77)$$

We are looking for waves that travel along the axis of the waveguide periodically as $e^{i\omega t - \gamma z}$. The real part of γ is the decay rate of the wave and the complex part is the wave vector $2\pi/\lambda$. Cancelling out the time dependence,

$$\nabla^2 \vec{E} = -\omega^2 \mu\epsilon \vec{E} \equiv -k^2 \vec{E} \quad \nabla^2 \vec{H} = -k^2 \vec{H} \quad . \quad (7.78)$$

The Laplacian can be separated into components that are transverse to the waveguide axis and that are axial, taken here to be in the \vec{z} direction:

$$\begin{aligned}\nabla^2 \vec{E} &= \nabla_{\text{T}}^2 \vec{E} + \frac{\partial^2 \vec{E}}{\partial z^2} \\ &= \nabla_{\text{T}}^2 \vec{E} + \gamma^2 \vec{E} \quad .\end{aligned}\quad (7.79)$$

This turns equations (7.78) into *Helmholtz' equations* for the transverse dependence of the field

$$\nabla_{\text{T}}^2 \vec{E} = -(\gamma^2 + k^2) \vec{E} \equiv -k_c^2 \vec{E} \quad \nabla_{\text{T}}^2 \vec{H} = -k_c^2 \vec{H} \quad , \quad (7.80)$$

defining the characteristic wave vector k_c . Along with this, the curl equation for a periodic signal

$$\nabla \times \vec{E} = -i\omega\mu\vec{H} \quad (7.81)$$

has transverse components

$$\begin{aligned}\frac{\partial E_z}{\partial y} - \underbrace{\frac{\partial E_y}{\partial z}}_{-\gamma E_y} &= -i\omega\mu H_x & \frac{\partial H_z}{\partial y} - \underbrace{\frac{\partial H_y}{\partial z}}_{-\gamma H_y} &= i\omega\mu E_z \\ \underbrace{\frac{\partial E_x}{\partial z}}_{-\gamma E_x} - \frac{\partial E_z}{\partial x} &= -i\omega\mu H_y & \underbrace{\frac{\partial H_x}{\partial z}}_{-\gamma H_x} - \frac{\partial H_z}{\partial x} &= i\omega\mu E_y\end{aligned}\quad (7.82)$$

which can be rearranged as

$$\begin{aligned}E_x &= -\frac{1}{k_c^2} \left(\gamma \frac{\partial E_z}{\partial x} + i\omega\mu \frac{\partial H_z}{\partial y} \right) & H_x &= \frac{1}{k_c^2} \left(i\omega\epsilon \frac{\partial E_z}{\partial x} - \gamma \frac{\partial H_z}{\partial y} \right) \\ E_y &= \frac{1}{k_c^2} \left(-\gamma \frac{\partial E_z}{\partial x} + i\omega\mu \frac{\partial H_z}{\partial y} \right) & H_y &= -\frac{1}{k_c^2} \left(i\omega\epsilon \frac{\partial E_z}{\partial x} + \gamma \frac{\partial H_z}{\partial y} \right) .\end{aligned}\quad (7.83)$$

If the axial components E_z, H_z are found from equations (7.80), they completely determine the transverse components through equations (7.83).

This set of equations admits three kinds of solutions: *Transverse Electric (TE)* with $E_z = 0$, *Transverse Magnetic (TM)* with $H_z = 0$, and *Transverse Electromagnetic (TEM)* with $E_z = H_z = 0$. For the TEM case, because the numerator in equations (7.83) vanishes, the only way the transverse components can be non-zero is for the denominator $k_c^2 = \gamma^2 + k^2$ to also vanish. This means that $\gamma = \pm ik = \pm i\omega\sqrt{\mu\epsilon} = \pm i\omega/c$, therefore TEM waves travel at the speed of light in the medium. $k_c = 0$ also reduces Helmholtz' equations to Laplace's equation, giving the static field solutions we used when studying transmission lines. Because in a hollow conductor the boundary is an equipotential, Laplace's equation implies that the field must vanish everywhere in the interior, therefore a TEM wave cannot be supported. Adding another conductor, such as the center lead in a coaxial cable, makes a TEM solution possible.

7.3.2 Rectangular Waveguides

Now consider a rectangular waveguide with width w in the x direction and height h in the y direction. The transverse equation for a TM wave is

$$\nabla_{\perp}^2 E_z = \frac{\partial^2 E_z}{\partial x^2} + \frac{\partial^2 E_z}{\partial y^2} = -k_c^2 E_z \quad . \quad (7.84)$$

Solving this subject to the boundary condition that the field must vanish at the conducting surfaces at $x = 0, w$ and $y = 0, h$ gives

$$E_z = A \sin(k_x x) \sin(k_y y) \quad , \quad (7.85)$$

where

$$\begin{aligned} k_c^2 &= k_x^2 + k_y^2 \\ k_x w &= m\pi \\ k_y h &= n\pi \end{aligned} \quad (7.86)$$

index the possible modes as a function of integers m and n . If we define a characteristic frequency ω_c associated with each mode by

$$\omega_c(m, n) = \frac{k_c(m, n)}{\sqrt{\mu\epsilon}} = \frac{1}{\sqrt{\mu\epsilon}} \left[\left(\frac{m\pi}{w} \right)^2 + \left(\frac{n\pi}{h} \right)^2 \right]^{1/2} \quad , \quad (7.87)$$

then we can find the propagation constant

$$\begin{aligned} \gamma^2 &= k_c^2 - k^2 \\ &= k_c^2 \left(1 - \frac{k^2}{k_c^2} \right) \\ &= k_c^2 \left(1 - \frac{\omega^2 \mu\epsilon}{\omega_c^2 \mu\epsilon} \right) \\ &= k_c^2 \left(1 - \frac{\omega^2}{\omega_c^2} \right) \quad . \end{aligned} \quad (7.88)$$

Therefore

$$\begin{aligned} \gamma &= k_c(m, n) \left[1 - \frac{\omega^2}{\omega_c(m, n)^2} \right]^{1/2} \quad \omega < \omega_c(m, n) \\ \gamma &= ik_c(m, n) \left[\left(\frac{\omega}{\omega_c(m, n)} \right)^2 - 1 \right]^{1/2} \quad \omega > \omega_c(m, n) \quad . \end{aligned} \quad (7.89)$$

When ω is less than the cutoff frequency ω_c for a mode, or equivalently when the wavelength λ is greater than the cut-off wavelength λ_c , γ is pure real and so the mode decays exponentially. When ω is greater than the cut-off frequency for a mode, γ is pure imaginary and the mode propagates. These modes are labeled TM_{mn} . Repeating this analysis for the TE wave by starting with the transverse equation for H_z shows that the TE and TM waves are degenerate with the same cutoff frequencies. At low frequencies nothing propagates; as the frequency is raised more and more modes can be excited, with the distribution of energy among them depending on how the waveguide is driven.

7.3.3 Circular Waveguides

For a waveguide with cylindrical symmetry, the transverse Laplacian for a TM mode is

$$\nabla_{\perp}^2 E_z = \frac{1}{r} \frac{\partial}{\partial r} \left(r \frac{\partial E_z}{\partial r} \right) + \frac{1}{r^2} \frac{\partial^2 E_z}{\partial \theta^2} = -k_c^2 E_z \quad , \quad (7.90)$$

which is solved by Bessel functions of the first (J_n) and second (N_n) kind [Gershenfeld, 1999a]:

$$E_z(r, \theta) = [AJ_n(k_c r) + BN_n(k_c r)][C \cos(n\theta) + D \sin(n\theta)] \quad . \quad (7.91)$$

The modes TM_{nl} are indexed by the order of the Bessel function n , and the root l of the Bessel function needed to make the field vanish at the boundaries. Although these frequencies can no longer be solved for analytically, for a coaxial cable a rough approximation for the TM modes is to ask that the wavelength be a multiple of radial spacing

$$\lambda_c \approx \frac{2}{n}(r_o - r_i) \quad n = 1, 2, 3, \dots \quad , \quad (7.92)$$

and for a TE mode that there be an integer number of azimuthal cycles

$$\lambda_c \approx \frac{2\pi}{n} \frac{a+b}{2} \quad (7.93)$$

[Ramo *et al.*, 1994]. In the section on transmission lines we studied the fundamental TEM mode. Because these higher-order modes have different velocities, if they are excited they will spread out the signal and hence limit the usefulness of the cable. This is why waveguides are usually designed to be operated with a single mode.

7.3.4 Dielectric Waveguides and Fiber Optics

Fortunately for telecommunications, waves can be guided by dielectric rather than conducting waveguides. The surface resistance that we saw in Section 7.2.1 represents a significant drag on a wave traveling in a waveguide, limiting the distance over which it is useful. Also, the requirement that the transverse dimension of a guide be comparable to the wavelength that is carried is easily met at microwave frequencies from ~ 1 to 100 GHz (~ 10 cm to 1 mm), but it becomes impractical at higher frequencies to work with macroscopic objects with microscopic dimensions. Both of these problems can be addressed by carrying light in a glass fiber instead of RF in a metal box.

To see how a wave can be guided by dielectrics, consider the slab geometry shown in Figure 7.8. We'll look for a mode confined in the y direction with a periodic z dependence of $e^{-\gamma z} \equiv e^{-i\beta z}$. Starting with the TE mode, the transverse equation for H_z becomes

$$\frac{d^2 H}{dy^2} = -(\gamma^2 + k^2)H_z = (\beta^2 - k^2)H_z \quad (7.94)$$

because there is no variation in the x direction. Depending on the relative magnitudes of β and k this can have oscillatory or exponential solutions. For the solution to be confined, and reflect the symmetry of the structure, we require the wave to be exponentially damped

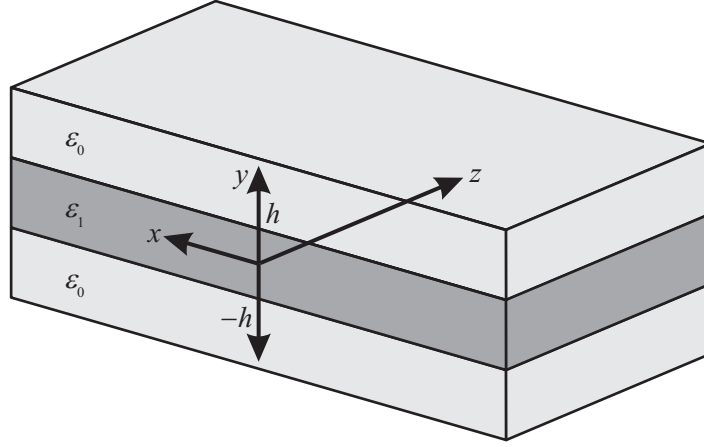

Figure 7.8. A dielectric slab waveguide.

outside of the slab, and periodic across it:

$$\frac{d^2 H_z}{dy^2} = \begin{cases} (\beta^2 - k_0^2) H_z & (|y| > h) \\ -(k_1^2 - \beta^2) H_z & (|y| < h) \end{cases} \quad (7.95)$$

The symmetric solution to this is

$$H_z = \begin{cases} Ae^{-(\beta^2 - k_0^2)^{1/2}(|y| - h)} \equiv Ae^{-a(|y| - h)} & (|y| > h) \\ B \cos((k_1^2 - \beta^2)^{1/2}y) \equiv B \cos(by) & (|y| < h) \end{cases} \quad (7.96)$$

Now the boundary conditions require continuity of the field at the interfaces, hence

$$A = B \cos(bh) \quad (7.97)$$

The transverse components are found from equations (7.83), which for E_x is

$$\begin{aligned} E_x &= -i \frac{\omega \mu}{k_c^2} \frac{\partial H_z}{\partial y} \\ &= -i \frac{\omega \mu}{k^2 - \beta^2} \frac{\partial H_z}{\partial y} \\ &= \begin{cases} -i \frac{\omega \mu}{a} A e^{-a(y-h)} & (y > h) \\ i \frac{\omega \mu}{b} B \sin(by) & (|y| < h) \\ i \frac{\omega \mu}{a} A e^{-a(-y-h)} & (y < -h) \end{cases} \quad (7.98) \end{aligned}$$

Equating these again at the boundaries,

$$\frac{A}{a} = \frac{B}{b} \sin(bh) \quad (7.99)$$

Now divide equation (7.99) by (7.97) to find

$$\frac{1}{a} = \frac{1}{b} \tan(bh) \quad (7.100)$$

This is a transcendental equation relating a and b , with multiple branches because of the

periodicity of $\tan(bh)$. A second relationship comes from the definitions of a and b

$$\begin{aligned} a^2 &= \beta^2 - k_0^2 \\ b^2 &= k_1^2 - \beta^2 \\ \Rightarrow a^2 + b^2 &= k_1^2 - k_0^2 \quad . \end{aligned} \quad (7.101)$$

a and b are restricted to a circle, with a radius given by the difference of the squares of $k^2 = \omega^2 \mu \epsilon$ in the media. For a and b to be real, the central slab must have the higher dielectric constant. The intersections of these circles with the branches of equation (7.100), found graphically or numerically, give the modes of the waveguide.

The analysis is similar for rectangular slabs that confine modes in both directions and for circular dielectric waveguides, although the imposition of these boundary conditions becomes a more difficult calculation [Yariv, 1991]. The result for the circular geometry is that there are two modes with axial H and E components, one called the HE with H dominant, and an EH mode with E dominant.

Dielectric waveguides for confining light are produced by depositing core doping material on the inside of a cladding glass tube and then drawing it down to a thin *optical fiber*. The first ones were *multi-mode* fibers that had core diameters many times the optical wavelength, resulting in very dispersive communications. In the next chapter we'll see that this can be understood as many different path lengths reflecting at the core-cladding interface. Because they're easier to make and connect to, these are still are used for short links and for many *optical sensors* that measure light coupling into or out of a fiber to determine local material properties [Merzbacher *et al.*, 1996], but long-haul communications uses *single-mode* fibers. The minimum absorption in optical glasses occurs at infrared wavelengths; by using very pure materials this has been reduced below 0.2 dB/km at 1.55 μm [Miya *et al.*, 1979; Takahashi, 1993]. This corresponds to a loss of 10^{-3} over 150 km, making long links possible without active repeaters.

So far we've been considering *step-index* fibers that have a constant dielectric constant in the core. By varying the core doping as a function of thickness it's possible to make *graded-index* fibers that use the radial profile to shape the modes. And an asymmetrical blank when drawn down produces a *polarization-preserving* fiber that retains the polarization of the light [Galtarossa *et al.*, 1994]. We've also assumed that the medium is linear, but the intense fields in the small fiber cores can excite nonlinear effects. We'll see more of this in the Chapter 9, but one of the most important applications is to the creation of *solitons* [Zabusky, 1981]. These are pulses that balance the material's intrinsic frequency-dependent dispersion with a nonlinear response that narrows the pulse, resulting in a stable shape that can propagate for long distances without changing. These can be sent across ocean-scale distances at Gbits/second without errors [Nakazawa *et al.*, 1993; Mollenauer *et al.*, 1996]. Using all of these tricks, fiber links have been demonstrated at speeds above 1 Tbit/second, approaching the limit of 1 bit/second per hertz of optical bandwidth [Ono & Yano, 1998; Cowper, 1998].

7.4 SELECTED REFERENCES

- [Ramo *et al.*, 1994] Ramo, Simon, Whinnery, John R., & Duzer, Theodore Van. (1994). *Fields and Waves in Communication Electronics*. 3rd edn. New York: Wiley.

A nice introduction to applied electromagnetics.

[Hagen, 1996] Hagen, Jon B. (1996). *Radio-Frequency Electronics: Circuits and Applications*. New York: Cambridge University Press.

[Danzer, 1999] Danzer, Paul (ed). (1999). *The ARRL Handbook for Radio Amateurs*. 76th edn. Newington, CT: American Radio Relay League.

Practical details for all aspects of RF design.

7.5 PROBLEMS

- (7.1) Cables designed to carry a low-frequency signal with minimum pickup of interference often consist of a twisted pair of conductors surrounded by a grounded shield. Why the twist? Why the shield?
- (7.2) Salt water has a conductivity $\sim 4 \text{ S/m}$. What is the skin depth at 10^4 Hz ?
- (7.3) Integrate Poynting's vector $\vec{P} = \vec{E} \times \vec{H}$ to find the power flowing across a cross-sectional slice of a coaxial cable, and relate the answer to the current and voltage in the cable.
- (7.4) Find the characteristic impedance and signal velocity for a transmission line consisting of two parallel strips with a width w and a separation h (Figure 7.4). You can ignore fringing fields by assuming that they are sections of conductors infinitely wide.

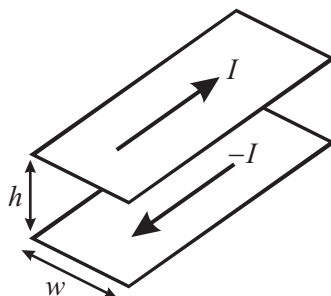

Figure 7.9. Transmission line for Problem 7.4.

- (7.5) The most common coaxial cable, RG58/U, has a dielectric with a relative permittivity of 2.26, an inner radius of 0.406 mm, and an outer radius of 1.48 mm.
- What is the characteristic impedance?
 - What is the transmission velocity?
 - If a computer has a clock speed of 1 ns, how long can a length of RG58/U be and still deliver a pulse within one clock cycle?
 - It is often desirable to use thinner coaxial cable to minimize size or weight but still match the impedance of RG58/U (to minimize reflections). If such a cable has an outer diameter of 30 mils (a mil is a thousandth of an inch), what is the inner diameter?
 - For RG58/U, at what frequency does the wavelength become comparable to the diameter?

-
- (7.6) Consider a 10 Mbit/s ethernet signal traveling in a RG58/U cable.
- (a) What is the physical length of a bit?
 - (b) Now consider what would happen if a “T” connector was used to connect one ethernet coaxial cable to two other ones. Estimate the reflection coefficient for a signal arriving at the T.